

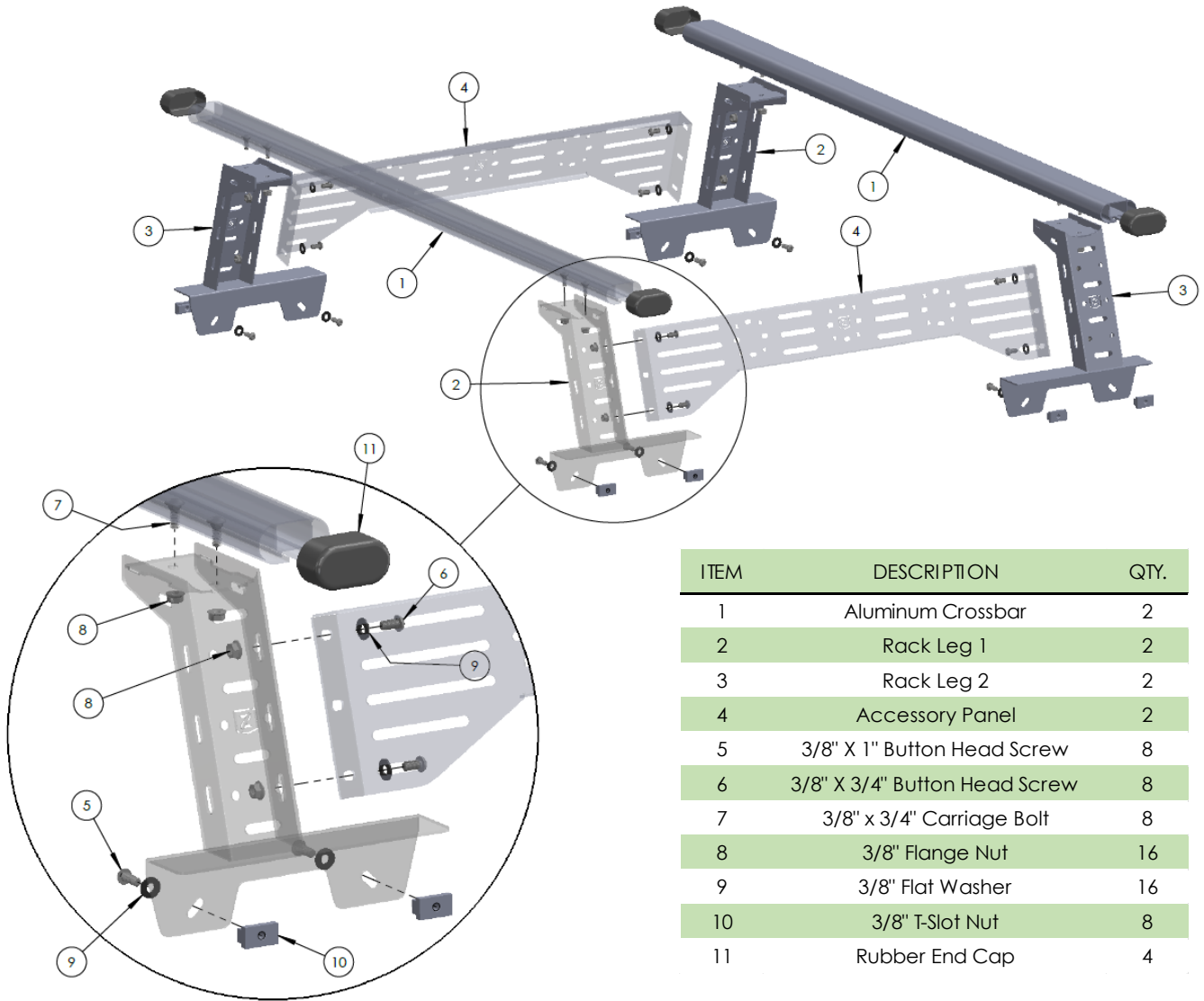

ZROADZ
OFF ROAD PRODUCTS

Assembly Overview



ITEM	DESCRIPTION	QTY.
1	Aluminum Crossbar	2
2	Rack Leg 1	2
3	Rack Leg 2	2
4	Accessory Panel	2
5	3/8" X 1" Button Head Screw	8
6	3/8" X 3/4" Button Head Screw	8
7	3/8" x 3/4" Carriage Bolt	8
8	3/8" Flange Nut	16
9	3/8" Flat Washer	16
10	3/8" T-Slot Nut	8
11	Rubber End Cap	4

NOTE: These instructions cover the following part numbers: Z879100,Z879101 and Z879002. Not all part numbers include all components pictured.



ZROADZ
OFF ROAD PRODUCTS

Tools Required

1. 7/32" Allen Wrench
2. 9/16" Socket or Wrench

Installation Instructions

1. Remove the plastic endcaps from the bed rails.
2. Slide all (8) T-Slot Nuts into the bed rail channels, (4) per side.
3. Place one of the Rack Legs into position on the bed side, and loosely thread (2) 3/8" x 1" Button-Head screws with (2) 3/8" washers, through the holes and into the T-Slot Nuts.
4. Tighten just enough that the Rack Leg sits flat against the bed rail, but loose enough to slide back and forth.
5. Repeat Steps 3-4 for the other Rack Legs. Ensure they are in the correct orientation as shown in the *Assembly Overview* and aligned with the Rack Legs on the opposite side of the bed.
6. Take one of the Aluminum Crossbars, and slide (4) 3/8" Carriage Bolts into the crossbar channel – (2) on each side of the crossbar.
7. Align the Carriage Bolts with the holes on top of the Rack Legs and place the Crossbar on top of the Rack Leg pair, feeding the (4) bolts through the holes.
8. Thread (4) 3/8" Flange Nuts onto the Carriage Bolts. Do not tighten.
9. Repeat Steps 6-8 for the other Crossbar.
10. Slide Rubber End Caps over the ends of the Crossbars.
11. Determine the desired spacing and positioning of your crossbars to suit your needs. **If installing optional Accessory Panels, skip to Step 13.*
12. Proceed to fully tighten all screws and nuts – bed rail Screws should be tightened first, and Crossbar nuts tightened last.

Accessory Panel Installation

13. Space the Rack Legs approximately 36" apart, measured between the panel mounting surfaces.
14. Use (4) 3/8" x 3/4" Button Head Screws, (4) Washers, and (4) Flange Nuts to mount each Accessory Panel between the Rack Legs. Ensure the Washers are used on the bolt head side, not the nut side.
15. Make sure the front surface of the Accessory Panel is flush with the front surface of the Rack Legs and proceed to tighten Panel screws and nuts.
16. Once Accessory Panel is installed, proceed to fully tighten all remaining screws and nuts – bed rail Screws should be tightened first, and Crossbar nuts tightened last.



ZROADZ
OFF ROAD PRODUCTS

Installation Pro-Tips

- The factory screws which attach the bed rail channel to the inner bed sides are prone to loosening over time. It is recommended to re-install these screws using a thread-locking compound such as blue Loctite.
- We recommend applying blue Loctite to the threads during installation.